

EN

COOKERS

PANORAMAGIC

CONVERSION KIT INSTALLATION INSTRUCTIONS

CHANGING THE INJECTORS

WARNING

“This conversion kit shall be installed by a qualified service agency in accordance with the manufacturer’s instructions and all applicable codes and requirements of the authority having jurisdiction. If the information in these instructions is not followed exactly, a fire, explosion or production of carbon monoxide may result causing property damage, personal injury or loss of life. The qualified service agency is responsible for the proper installation of this kit. The installation is not proper and complete until the operation of the converted appliance is checked as specified in the manufacturer’s instructions supplied with the kit.”

BURNER	GAs	INPUT RATE [Btu/h]	ORIFICE SIZE (1/100) mm	SIMMER RATE [Btu/h]	BY-PASS ORIFICE SIZE (1/100) mm
SR	NATURAL (A)	7000	120	1400	Adj.*
R	NATURAL (A)	10500	145	2000	Adj.*
DCC	NATURAL (A)	16500	190	6200	Adj.*
DUAL	NATURAL (A)	20000	75+190	6000	Adj.*
DUAL (only AUX)	NATURAL (A)	2800	75	900	Adj.*
SR	PROPANE (E)	7000	75	1400	32
R	PROPANE (E)	10500	90	2000	40
DCC	PROPANE (E)	16500	117	6200	75
DUAL	PROPANE (E)	20000	44+120	6000	27+60
DUAL (only AUX)	PROPANE (E)	2800	44	900	27

CHANGING THE INJECTORS

CAUTION: The gas supply shall be shut off prior to disconnecting the electrical power, before proceeding with the conversion. The kit for the gas conversion of the burners is relevant to the model of the appliance indicated on the label sticking to the first page of this booklet. The kit contains the number and type of orifices necessary for the conversion, all the necessary instructions, a label to stick onto the old one to show the new setting (see table 2) and the label to be completed by the technician who performs the conversion. The appliance is pre-adjusted in factory for the gas indicated on the label put on the gas inlet pipe. For the conversion to another gas refer to table 3.

The positions, types of burner and relevant orifices for the models included in this booklet are depicted in table 3. The only operation to perform after conversion to a gas different from that shown on the rating plate/label is the adjustment of the minimum gas flow. (See page 3 of this leaflet). After conversion remember to put the new gas indication label (supplied in the conversion kit) as close as possible to the existing rating plate, then check the regular ignition of the burners (see pages 3 and 4 of this leaflet, "Lighting the burners").

If the appliance is installed at an altitude exceeding 2,000 ft, a new set of orifices can be requested from the supplier or an authorised service parts distributor.

NOTE: Due to the lower atmospheric pressure at higher altitudes, foods tend to take longer to cook. Therefore, recipe adjustments should be made in some cases. In general, no recipe adjustment is necessary for yeast-risen baked goods, although allowing the dough or batter to rise twice before the final pan rising develops a better flavor. Try making the adjustments below for successful recipes. Take note of the changes that work best and mark your recipes accordingly. You may also consult a cookbook on high altitude cooking for specific recommendations.

WARNING: after first installation of the appliance, after gas conversion kit installation or after any service intervention concerning main gas parts of the appliance, make the leak test using water with soap on the gas connections in order to verify the correct installation. Do not use fire for gas leak testing. The test is valid if there is no bubble or foam build-up during a period of one minute.

CONVERSION KIT INSTALLATION INSTRUCTIONS

Table 3

CODE	NATURAL GAS	KIT NUMBER	PROPANE GAS	KIT NUMBER
UPMO9(6/F)D(W)S3		6CDNG		6CDLP
UPM12(8/F)D(W)S3		8CDNG		8CDLP



WARNING: Save the orifices removed from the appliance for future use

NOTE: To go back to the original set replace old orifices as shown



WARNING:

This conversion kit shall be installed by a qualified service agency in accordance with the manufacturer's instructions and all applicable codes and requirements of the authority having jurisdiction. If the information in these instructions is not followed exactly, a fire, explosion or production of carbon monoxide may result causing property damage, personal injury or loss of life. The qualified service agency is responsible for the proper installation of this kit. The installation is not proper and complete until the operation of the converted appliance is checked as specified in the manufacturer's instructions supplied with the kit.

BURNERS OF THE TOP

Replacement of the injectors

Procedure: SR - R - P • small solid top burner

- Remove the grill and the burners from the hob.
- Burners SR - R - P :

unscrew injectors "U" using a 7 mm spanner (fig. 1) and replace them with those for the new gas according to table number 2 on page 20. Save the orifices removed from the appliance for future use.

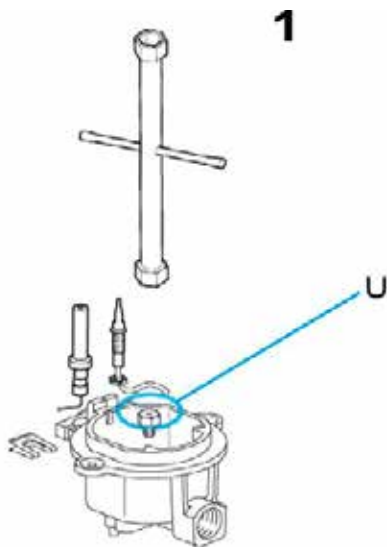

Procedure: DCC

- DCC – Dual burners: unscrew the 2 screws "P" and remove cover "C" fig.2.
- unscrew injectors "U" using a 7 mm spanner (fig.3, fig.4) and replace them with those for the new gas according to table number 1 below 13. Save the orifices removed from the appliance for future use.

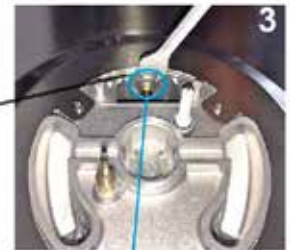

Procedure: DUAL

- Remove the grill and the burners from the hob.
- Unscrew injectors "U" using a 7-mm spanner (fig. 8, fig 10) and replace them with those for the new gas according to table number 3. Save the orifices removed from the appliance for future use.

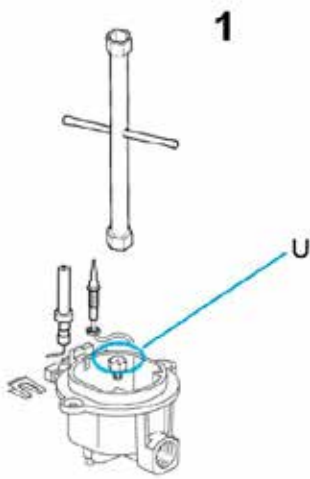

ADJUSTING THE MINIMUM GAS FLOW

When installing the cooker you must check that the minimum gas flow of the burners on is correctly regulated. If the type of gas is changed it is indispensable to adjust the minimum flow. The adjustment procedure is as follows.

Burners on the hob (fig. 13)

1. Light one burner at a time and turn the flame up to maximum
2. Remove the knob of the corresponding gas tap and insert screwdriver in the screw as shown in figure 14a or 14b (DUAL).
3. Turn the tap to minimum position.
4. Unscrew, turning to the left, to increase the flame, or screw to the right to decrease it
5. If a liquid gas is used (Butane - Propane), the regulating screw must be fully screwed in

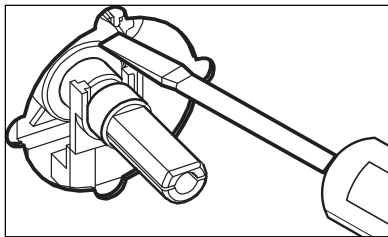

Figure 13

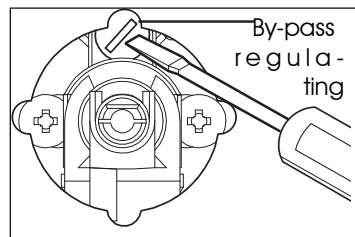

Figure 14a

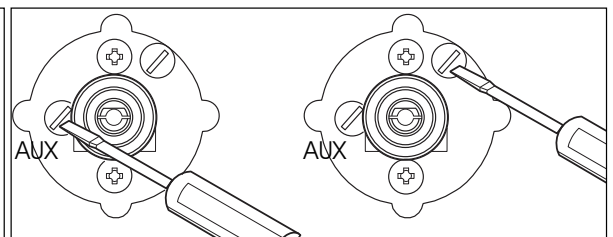

Figure 14b (DUAL)

LIGHTING THE BURNERS

The index above the knobs will help you to find the corresponding burner. Press the knob by turning it counterclockwise and bring it to the ignition position; keep the knob pressed for about 5 seconds so that upon its release the flame remains alight. In case of unsuccessful ignition wait 5 minutes before relighting and repeat the operation.

LEGEND

Symbol			
Function	off	maximum	minimum
Knob			
Index			

Recommended pans according to burner size:











Burners	ID	Diameter Ø (cm)
Burners	SR	10 ÷ 20
Large	R	20 ÷ 24
Ring	TC/DCC	22 ÷ 28
Dual - Ring	DUAL	24 ÷ 30

IGNITION OF THE “DUAL” BURNER

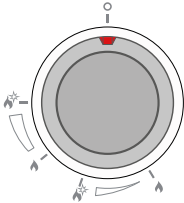
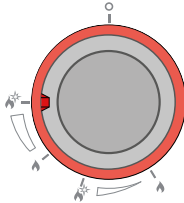
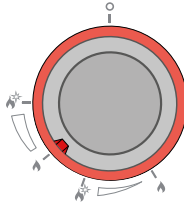
Identify the knob with the help of the index near the knobs. Press and turn the knob to the symbol (maximum) for 5 seconds. Once the burner is on, by turning the knob counterclockwise it gets to its first block that corresponds to the middle one. By applying a bit of force, the first block is overrun and the outer ring goes out leaving only the little central burner (called AUXILIARY) turned on. To adjust the auxiliary burner on minimum, rotate the knob counterclockwise until it stops. At this point, to turn the burner back on, rotate the knob clockwise up to the desired value.

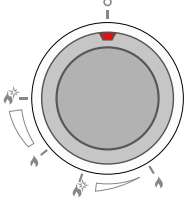
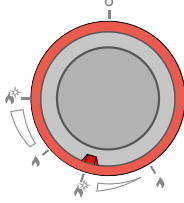
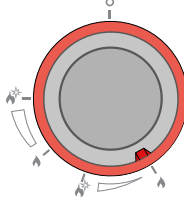
LEGEND

Symbol			
Function	off	maximum	minimum
DUAL 			
AUX 			
Index			

ADJUSTMENT OF THE PRESSURE REGULATOR FOR USE WITH DIFFERENT TYPE OF GAS

The pressure regulator supplied with the appliance is a convertible type pressure regulator for use with Natural Gas at a nominal outlet pressure of 5" w.c. or Propane at a nominal outlet pressure of 10" w.c. and it is prearranged from the factory to operate with one of these gas/pressure as indicated in the pre-arranging labels affixed on the appliance, package and instruction booklet.

If Natural gas is converted to Propane, also the by-pass orifice has to be changed. The regulating screw of the by-pass orifice must be fully screwed in.

To convert the regulator (Fig.6 and Fig.7) for use with the other gas (different from the one for which it is pre-arranged) it is enough perform the following operations:

1. Unscrew by hand the upper metal stopper of the regulator.
2. Unscrew by hand the white plastic piece screwed under the above mentioned metal stopper, afterward screw it again in opposite way under the metal stopper (for gas reference see the written "Propane" and "NAT" with relative indicating arrows on the white piece).
3. Screw again by hand the metal stopper in the original position on the regulator. Operating in this way the gas regulator is converted for use with the other gas/pressure

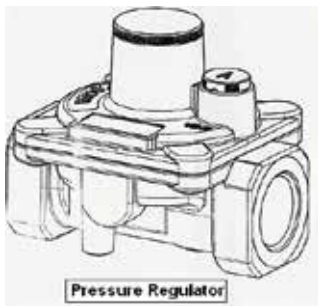

Fig. 6 Pressure regulator

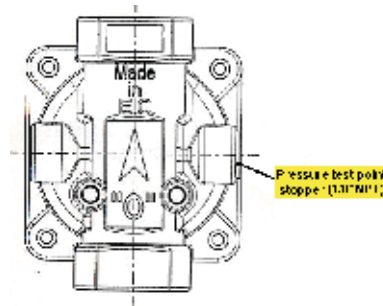

Fig. 7 Pressure regulator; pressure test-point stopper is pointed out

See the table below for gas supply pressure requirements.

Gas Type	Manifold Pressure (WC)	Min. Gas Supply Pressure (WC)	Max. Input Pressure
Natural	5	6	1/2 psi
PROPANE	10	11	1/2 psi

In the line pressure is in excess of that amount, a step down regulator will be required, the appliance must be disconnected from the GAS supply piping system during any pressure testing of that system.

CORRECT RELATIONSHIP BETWEEN THE IGNITER AND THE MAIN BURNER

UPM09D(W)S3

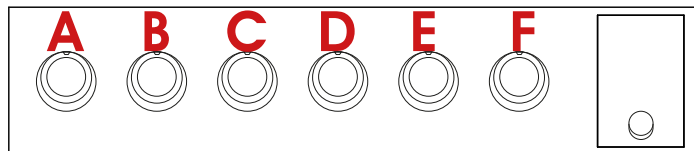
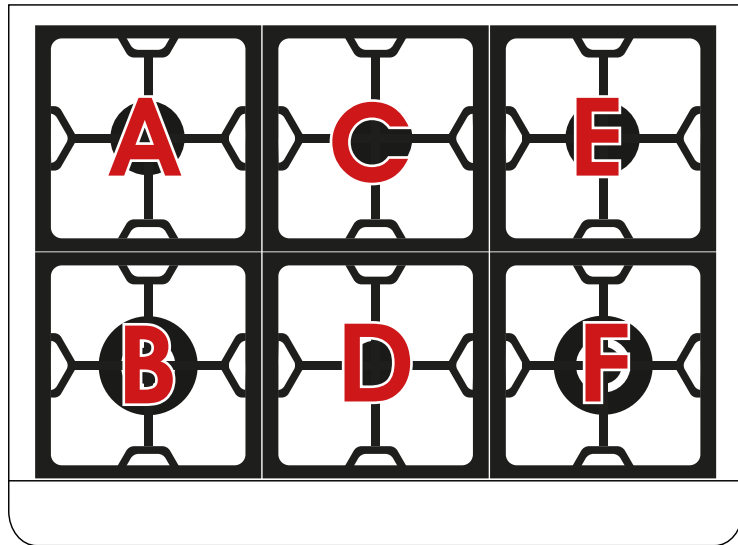

UPM128D(W)S3

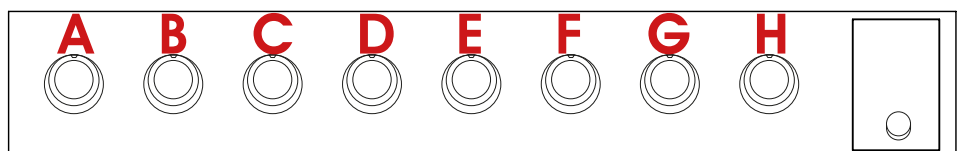
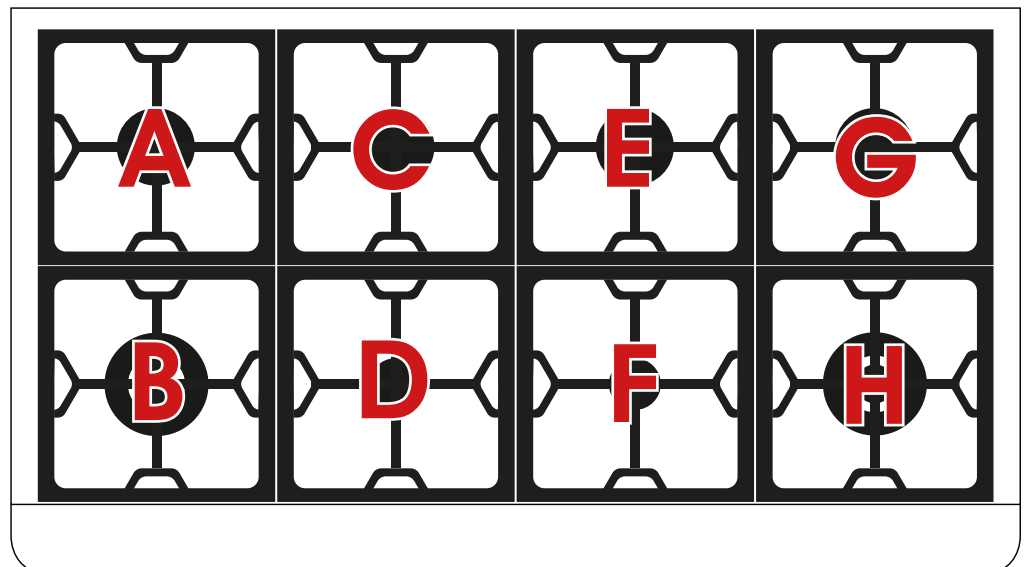

INJECTORS FOR THE APPLIACE INSTALLED AT AN ALTITUDE EXCEEDING 2000 ft

BURNER	GAS	ORIFICE SIZE (1/100) mm
SR	NATURAL (A)	117
R	NATURAL (A)	141
DCC	NATURAL (A)	185
DUAL	NATURAL (A)	74+185
DUAL (only AUX)	NATURAL (A)	74
SR	PROPANE (E)	74
R	PROPANE (E)	87
P	PROPANE (E)	88
DCC	PROPANE (E)	112
DUAL	PROPANE (E)	42+117
DUAL (only AUX)	PROPANE (E)	42

INSTRUCTIONS TO AFFIX THE CONVERSION KIT LABEL

area for affixing
the conversion plate

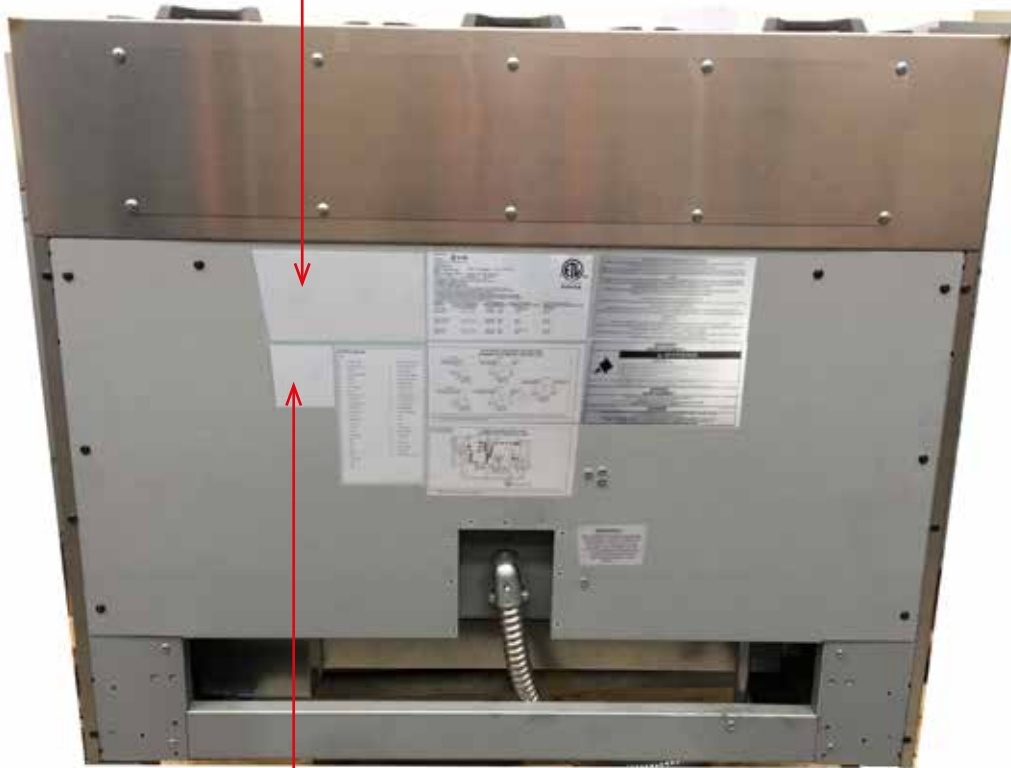

area for identification label
of the service agency making
the conversion

